

## Separate Counter **SC1 Series**

**BLOP-SC1**  
**CLOP-SC1**

### Instruction Manual

(Current as of July 2012)

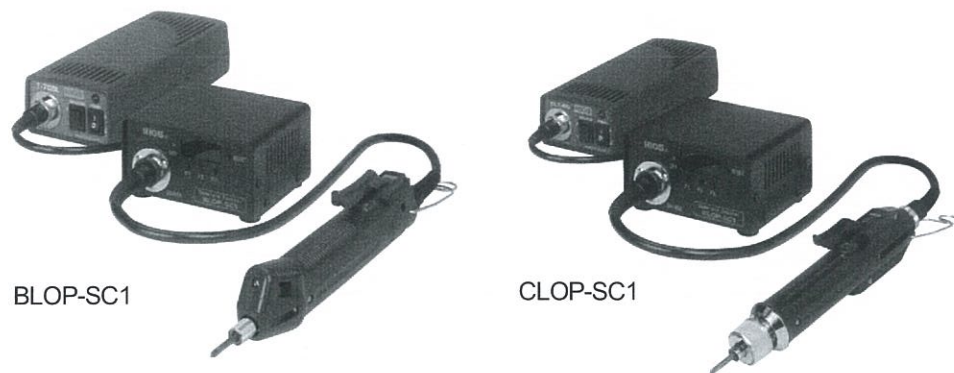

	(Page)
■ Introduction	2
Outline	
SC1 Series functions, other	
■ Precautions for Use	3, 4
Precautions for Installation Area and Use	
■ Unit Specifications	4
■ Power and Driver Compatibility with the SC1 Series	5
■ Main Functions and Terminology	6, 7
■ Name of Each Part and Functional Description	8 to 11
Front Panel	8, 9
Rear Panel	10, 11
■ Default Settings	12 to 16
■ Basic Timing Chart	17
■ Total Counter SC1	
Outline of Basic Operations	18 to 20
■ Basic Usage	21 to 26
1. Ordinary power mode	21
2. Continuous counter mode	21, 22
3. Counter mode	22, 23
4. Multi-counter mode	24, 25
■ Troubleshooting	26

**Hios Inc.**

111-6, Akiyama, Matsudo, Chiba Pref. Japan, 207-2223

TEL: 047-392-2001 FAX: 047-392-7773

## Introduction

Thank you for purchasing the separate counter series **BLOP-SC1** and **CLOP-SC1**. Please read through this instruction manual carefully before use for proper operating instructions. Store this manual in a safe place for future reference.

### ■ Outline

The counter function can be added by connecting a HIOS driver power supply to the SC1 Series.

- The BLOP-SC1 can be connected to the T-30BL and T-70BL power supply for brushless drivers.
- The CLOP-SC1 can be connected to the CLT series and MC-70L power supplies.

### ■ SC1 Series Count Function

1. The number of screws to be tightened for a particular work piece can be set to between 1 and 99 for this unit. The remaining number of screws to be tightened is counted down in the display after each screw has been tightened.
2. A buzzer sounds after the final screw has been tightened to prevent the operator from forgetting to tighten screws. This also allows the operator to check whether work on a particular piece of work is complete.
3. The auto reset function automatically updates the unit's display when all screws have been tightened and can be used to prevent the driver from being used until the SET signal is received when the next work piece is set.
  - \* The driver cannot be used while in standby mode.
4. Prevents tightening checks and increased tightening (tightening a screw a second time) from being counted.
5. The unit can be set so that it does not count screws that have not been properly seated and cross-threaded screws.
  - \* Varies with the type of work being performed.

### ■ Other Functions

1. Control of External Equipment
  - The number of completed work pieces can be counted by controlling solenoid valves used to hold the work piece in place or commercially available total counters.
2. Multi-count Mode using the External Connection Function
  - Several screwdrivers with differing screw tightening capabilities or output torque may be used in cell production, with only the appropriate electronic screwdrivers operational in the order they are to be used. This prevents careless mistakes made by operators.

### ■ Installation Area

- Use a HIOS power supply that is compatible with the driver being used.
- Install the unit in a temperature and humidity controlled room with adequate ventilation.
- Install the unit in an area that is not subjected to dust, dirt or metal fragments.
- Install the unit in an area that is not subjected to water or oil.
- Do not place heavy items on top of the unit or stack units on top of one another.
- Select a safe installation area that is free from vibrations.
- If the unit is to be installed in an elevated location, ensure that it is fixed firmly so that there is no danger of the unit falling.
- Do not install the unit near other high-voltage equipment or electronically noisy environments.
- Do not use input and output cables that are longer than required or knot them. Doing so may result in incorrect readings.

### ■ Precautions for Use

- Ground the HIOS power supply connected to the unit and use the power supply within the specified rated power and voltage.
- Ensure that loads connected to the output terminals on the rear panel terminal block do not exceed the rated load.
  - Exceeding the rated load can cause a malfunction.
- If external equipment connected to the +DC 24 V output terminal or input/output terminals on the rear panel terminal block are affected by the electromagnetic induction of relays and solenoid valves coils, noise prevention in the form of reverse voltage absorbing diodes should be used. Equipment may operate incorrectly or malfunction if noise prevention is not used.
- Do not connect the +24 V DC terminals on the rear panel terminal block to the GND terminal. Doing so will result in a malfunction.
- Do not connect the +24 V DC terminals on the rear panel terminal block to any output terminal. Doing so will result in a malfunction.
- A common GND terminal should be used if the unit's functions are used to power external equipment with an external power supply. Equipment may operate incorrectly or malfunction if a common GND is not used.
- Do not provide additional voltage to the input terminals. Do not provide voltage or current to the output terminals that exceeds their rated values. Doing so can result in a malfunction.
- Use the unit in temperatures of 5°C to 40°C and 80% or less humidity (with no condensation).
- Always hold the plug when connecting or removing the power cord or driver cord.
- Do not pull the cords, drag them across oil or sharp edges, or place heavy objects on top of them. Doing so may result in severed wires or malfunctions.
- The overload protection function of the HIOS power supply connected to the unit will operate if the driver remains locked or becomes overloaded. Please note that work involving repeated overloads will increase load over the capacity of the connected HIOS power supply and electronic driver. If the unit malfunctions with repeated overloads during normal operations, immediately stop using the unit, turn off the main power switch of the HIOS power supply connected to the unit, remove the power cord from the power outlet and bring the unit to our service department.
- If the unit overheats, turn off the main power switch of the connected HIOS power supply, remove the power cord from the power outlet and let the unit cool down. The unit may be used again once it has cooled down. If it overheats again immediately stop using the unit, turn off the main power switch, remove the power cord from the power outlet and bring the unit to our service department.
- When tightening screws on plastic work pieces that may have a lot of static electricity buildup,

remove electricity before starting work. If electricity is not removed, static electricity may flow from the end of bit, resulting in incorrect operation.

- Do not drop or subject the unit to strong shocks.
- Do not connect drivers other than those manufactured by HIOS. Doing so will result in a malfunction.
- Turn the main power switch of the HIOS power supply OFF if the unit is not used for a prolonged period of time, and remove the power plug.
- Never dismantle or modify the unit. Doing so may result in a malfunction and void the warranty or make it impossible to be repaired.

### ■ Specifications

Model		BLOP-SC1 · CLOP-SC1
Primary Side	Input Voltage	DC 20 V to 31 V
Power Consumption		5 W / during DC 31 V output
Secondary Side	Output Voltage	Depends on the connected HIOS power supply (same as the input voltage)
Dimensions (mm)		110 (W) x 100 (D) x 55 (H), does not include protrusions
Weight (kg)		0.6 kg
Accessories		1 instruction manual, 1.5 m driver cord (5P), 8 crimp terminals

### ■ Power and Driver Compatibility with the SC1 Series

#### • BLOP-SC1

##### Power for Brushless Driver

T-30BL (for BL-2000/BL-3000)

T-70BL (for BL-2000/BL-3000/BL-5000/BL-7000)

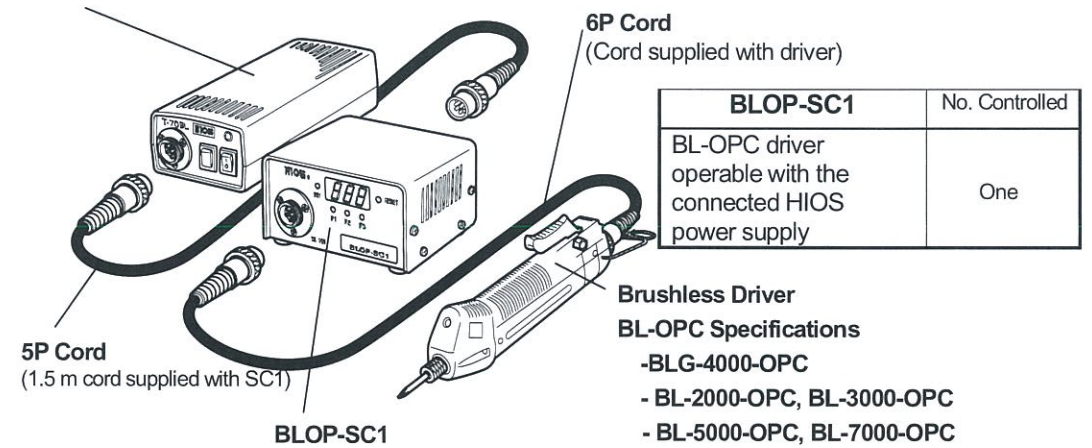

#### •CLOP-SC1

##### Power for CL, SS and α Drivers

CLT-30, CLT-60, CLT-100, CLT-75 (for CL-9000)

MC-70L + CB-105

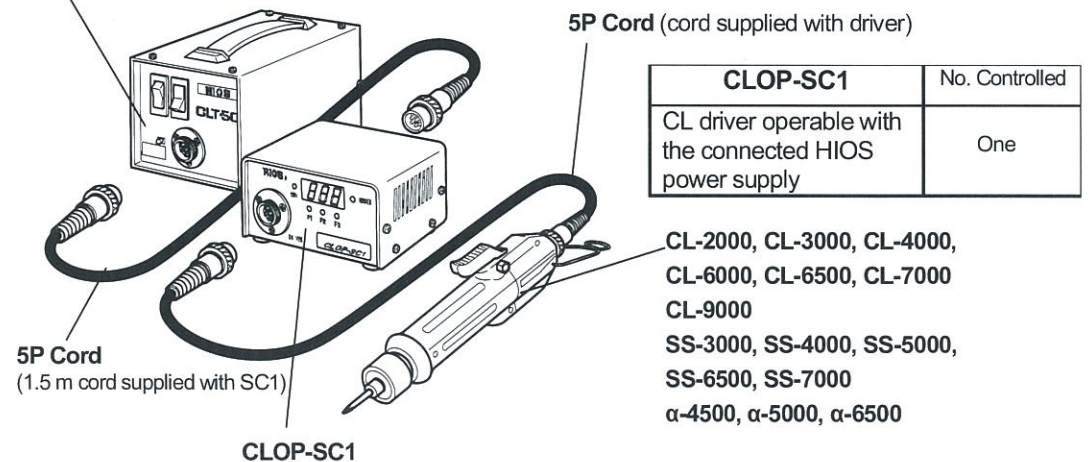

(Note) If multiple power supplies are to be used, one SC1 is required for each connected driver.

## ■ Main Functions and Terminology

### 1. Tightening Check

- Refers to the act of tightening screws a second or third time to check that the screws have been tightened properly or to completely seat a screw. The terms second tightening or increased tightening may also be used for the same meaning.

### 2. Torque Up

- After each screw has been tightened, the torque is increased to the set level before the electronic driver clutch is disengaged.
- The unit will recognize the first torque up operation after the normal rotation\* count timer elapses as the final torque up for screw tightening. Please set the count timer so that it does not count down after torque up operations for tightening checks.

\* The normal rotation count timer is hereinafter referred to as the count timer.

### 3. Signal Input Method

- A photocoupler is used as the signal input method. The input current is a maximum of 10 mA or less.
- If an open collector connection is used, connect collectors to each input terminal and the emitter to the GND terminal.

#### <Caution>

- Do not provide additional voltage to the input terminals.  
Use input resistance of 10  $\Omega$  or less.
- Add a reverse voltage absorbing diode to the input contact point relay coil.
- Use noise prevention measures when using external equipment (refer to Image 1).

### 4. Signal Output Method

- The output signal method is open collector output with a maximum rated load of DC 30 V/80 mA.

#### <Caution>

- Do not provide addition voltage to the output terminals.
- Add a reverse voltage absorbing diode to the coil if a relay or solenoid valve is used.

### 5. BL-OPC Specifications (electronic driver)

- BL-OPC specifications refer to BL (brushless) electronic drivers with output functions that have normal rotation, reverse rotation and torque up signal output functions.

### 6. Screw Tightening Over and Screw Tightening Complete

- Screw tightening over in the instruction manual refers to when one screw has been tightened completely.
- Screw tightening complete in the instruction manual is when all screw tightening operations for a certain work piece have been completed.

### 7. Electronic Driver Operating Control

- The counter mode and multi-counter mode of this unit allows or prohibits electronic driver operation with the SET signal.

### 8. Counter Mode

- The number of screws to be tightened can be seen in the count down display as each screw is tightened.

### 9. Multi-counter Mode

- In addition to the counter mode, multiple electronic drivers can be operated in a predetermined order with a relay type system when there are several screws with different torque settings or bit tightening conditions on a single work piece.
- Connect the same number of units as the number of electronic drivers used in a daisy chain setup as shown in example 3.

#### <Caution>

- When using electronic drivers in predetermined order, other electronic drivers cannot be operated to prevent them from being used.

## <Front Panel (BLOP-SC1)>

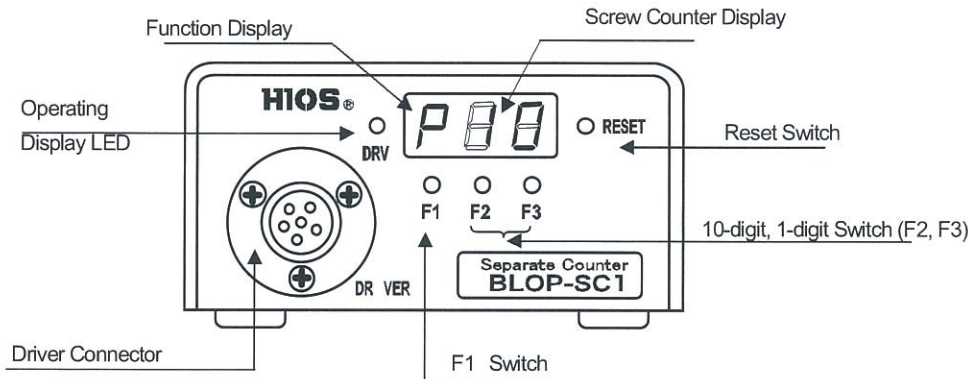

## <Front Panel Description>

### - Driver Connector

- Driver cord connection.
- 6-terminal connector for BL, 5-terminal connector for CL drivers.

### - Operating Display LED

- Turns green when the power is ON.
- Turns orange when the electronic driver can be used.
- \* The VALVE signal (rear panel) is output at the same time.

### - Screw Counter Display

- Displays the initial number of screws to be tightened. After counting commences, the remaining number of screws to be tightened is displayed.
- The number of screws to be tightened counts down as each screw is tightened.

### - Function Display

- Displays the symbol corresponding to the mode being set when setting the counter.

### - Reset Switch (Reset)

- Resets the count function, stops the VALVE signal output and releases the lock on the work by external equipment connected to the unit.
- The reset switch works in the same way as the reset terminal on the rear panel.
- Pressing the reset switch during or after setting the number of screws to be tightened displays the set number of screws.

### - F1 Switch (Function Setting)

- Enters function switch mode when the switch is held for 1 second or more after reset (function display "P").
- A buzzer will sound twice when the switch is held for 1 second or more while in function switch mode to signal that function switch is complete.

### - 10-digit, 1-digit Setting Switch (F2, F3)

- Increases digits by one each time the switch is pressed.
- The value that can be set will vary depending on the function.

#### (1) Count Set Mode (function display "P")

- The number of screws to be tightened can be set to any value between 1 and 99.
- Use the change set value switch (F2, F3) to jump between units of 10 and 1.
- Please note the unit will not recognize a set value of 00 (a warning buzzer will sound).

#### (2) CN-T (count timer) Set Mode (function display "C")

- The range of settings is between 0.00 and 0.99 seconds.
- This setting switch prevents tightening checks and increased tightening of screws from being counted a second time.
- The driver can only be used when the count timer has been set, regardless of other settings. A buzzer will sound for a short time if the driver is used to tighten screws and torque up operations exceed the CN-T setting. Set the time on the count timer using the buzzer as a guide while performing a tightening check.

#### (3) WS-T (Work set timer) Set Mode (function display "L")

- The range of settings is between 0.0 and 3.9 seconds.
- Sets the time before the driver can be used after the terminal block SET signal has been received and the VALVE signal is output.
- Set the time on the work set timer to suit the work conditions.

#### (4) WR-T VR (work reset timer) Set Mode (function display "R")

- The range of settings is between 0.0 and 3.9 seconds.
- Sets the space of time from when work is completed up until the VALVE signal is stopped to prevent use of the driver.
- Set the time on the work set timer to suit the work conditions.

#### (5) RCN-T (reverse rotation count timer) Set Mode (function display "R")

- The range of settings is between 0.1 and 1.0 seconds.
- Sets the time up until reverse rotations are counted.
- Set the time on the work reset timer using the time until reverse rotation operations are counted as a guide.

### <Caution>

- The **reverse rotation count timer** can only be used with brushless drivers. This function can only be used when RCN-T is enabled in (6) System settings below.

#### (6) System Set Mode (function display "D")

- The settings available are as follows.
  - 1) DSP (controls the remaining screw count display: ON = displayed, OFF = not displayed)
  - 2) BUZZ (controls the buzzer sound: ON = buzzer sound on, OFF = buzzer sound off)
  - 3) RCN-T (controls the reverse rotation count function: ON = enabled, OFF = disabled)
- \* **Only available with BL-OPSC1**

- 4) EVERON (controls normal counter operation: ON = enabled, OFF = disabled)
- 5) TUP BUZZ (controls the buzzer during torque up operations; ON = enabled, OFF = disabled)
- 6) COUNTER OFF (stops all counter functions: only available for the power supply)

**Note) reverse rotation count timer (enabled only with the BL-OPC driver)**

- The reverse rotation count timer is a timer to set the reverse rotation count up determination time.
- The unit recognizes that a screw has been loosened only when the electronic driver is in reverse rotation longer than the time set with the reverse rotation count timer, and counts up the number of screws in the counter display.

**Note)**

- The unit will count up reverse rotations made when the final screw tightening count is "00", regardless of the reverse rotation count timer setting, as even a brief reverse rotation will be recognized by the unit as loosening a screw.
- The reverse rotation count is a function designed to cancel a screw count resulting from a torque up operation. After the count has been reversed following a reverse rotation, it will not be possible to reverse the screw count again until the count down is resumed following normal rotation.

**<Rear Panel: same for BLOP-SC1/CLOP-SC1>**

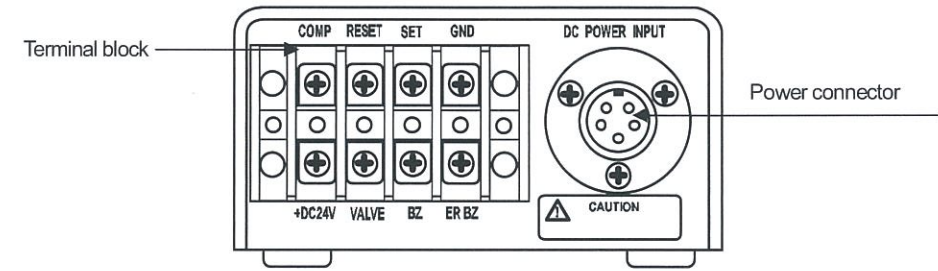

**<Rear Panel Description>**

**- HIOS Power Connector**

- Driver cord connection (5-terminal).
- Never connect a power supply other than a HIOS power unit.
- Use a power supply with a capacity that suits the driver being used.
- (An unsuitable power supply may overload the unit or affect the performance of the driver.)

**- GND terminal**

- Ground terminal

**- SET terminal**

- Input terminal for the work piece SET signal
- The operating display LED on the front panel will light up after the SET signal has been received and the time set on the work set timer has elapsed allowing the electronic driver to be used. The VALVE signal will be output at the same time.
- Connect an external work detection switch to the unit to pull the set terminal voltage to ground.

**<Caution>**

- In order to prevent incorrect operations, the electronic driver cannot be used until the operating display LED has turned orange. If EVERON (continuous counter operation mode) has been enabled in the system settings, the driver can be used when the power is ON and the operating display LED is orange.

**- RESET terminal**

- RESET signal input terminal
- The RESET terminal is used to reset the counter function and output of the VALVE signal to release the lock applied to the work by external equipment connected to the unit.
- The RESET terminal works in the same way as the reset function on the front panel.
- Connect an external RESET switch to the unit to pull the RESET terminal voltage to ground.

**- COMP terminal**

- Output terminal for the COMP signal after work is complete.

- A signal will be output for 0.1 seconds once work is complete and time on the work reset timer has elapsed.
- The output method is open collector output with a maximum rated load of DC 30 V/80 mA.
- Connect a total counter to count the number of completed work pieces.

#### - +DC 24 V terminal

- Power terminal for external equipment. The power capacity has a maximum rated output of DC 24 V/0.2 A.

#### - VALVE terminal

- Output terminal for external equipment and control signals.
- Use this terminal to control solenoid valves (DC 24 V) of external equipment such as clamps and vices uses to hold the work.
- Connect the solenoid (+) terminal of external equipment to the +DC 24 V terminal and the solenoid valve GND terminal to the VALVE terminal.
- If external equipment with different power supply voltages is used, use a common GND terminal and external power supply.
- Add a reverse voltage absorbing diode to induced loads such as solenoid valves on external equipment.
- The output method is open collector output with a maximum rated load of DC 30 V/80 mA.

#### - BZ terminal

- Together with the buzzer sound, the signal is output in time with the work reset timer.
- The signal from the BZ terminal is output regardless of the mode settings. (however the signal is not output when in COUNTER OFF mode)
- If external equipment with different power supply voltages is used, use a common GND terminal and external power supply.
- Add a reverse voltage absorbing diode to the induced loads such as solenoid valves on external equipment.
- The output method is open collector output with a maximum rated load of DC 30 V/80 mA.

#### - ER BZ terminal

- This signal is output if the work set signal is interrupted before screw tightening is complete.
- The unit is operational as normal until the remaining screws have been tightened.
- ER BZ output does not stop until reset or countdown is complete.
- If external equipment with different power supply voltages is used, use a common GND terminal and external power supply.
- Add a reverse voltage absorbing diode to the induced loads such as solenoid valves on external equipment.
- The output method is open collector output with a maximum rated load of DC 30 V/80 mA.

## ■ Default Settings

\* These default settings use the counter mode as an example, however are the same for other MODE settings.

Set the default settings before using the unit, and set MODE to suit any further operations.

### 1. Connection

- (1) Connect the driver cord to the unit's metallic connector.
- (2) Connect the appropriate HIOS power supply for the driver to the metallic power input terminal on the rear panel of the unit.

### 2. Setting procedure

- (1) Check the MODE settings (factory default settings)
  - Turn the main external power switch "ON".
  - Press the F1 switch and Reset switch at the same time, and release the Reset switch only.
  - The F1 switch buzzer (beeping) will sound. Continue pressing (for 1 second or more) until "P" is displayed in the function display.
- (2) Press the F1 switch until "□" is displayed.
  - Check that the setting display is on "02".
- (3) Press the Reset switch.

### 3. Work procedures

- (1) Turn the main switch of the external power supply "ON".
- (2) Set the work set timer.
  - Press the F1 switch and Reset switch at the same time, and release the Reset switch only. The F1 switch buzzer (beeping) will sound. Continue pressing (for 1 second or more) until "P" is displayed in the function display.
  - Using the F1 switch, change to work set timer mode (function display "L") and set the timer using the F2 (10-digit) and F3 (1-digit) switches. (range of settings: 0.0 to 3.9 seconds)
  - The VALVE signal is output after the time set on the work set timer has elapsed (time up). (this signal is output continuously until the time is reset or the count is complete)
  - Pressing the F1 switch after settings are complete will move to the next item to be set.
  - After all settings are complete, press the F1 switch for 1 second or more. A buzzer will sound twice and the setting mode will end.
- (3) Using the F1 switch, change to count timer setting mode (function display "C"), and while carrying out tightening checks, set the time on the count timer using the F2 (10-digit) and F3 (1-digit) switches. (range of settings: 0.00 to 0.99 seconds)

- A buzzer will sound for a short time if torque up is attempted after the time set on the count timer has elapsed. While there are usually individual differences, carry out tightening checks continuously and set the operating time so that count down is not performed.  
(the factory default setting for the count timer is 0.15 seconds)
- Pressing the F1 switch after settings are complete will move to the next item to be set.
- After all settings are complete, press the F1 switch for 1 second or more. A buzzer will sound twice and the setting mode will end.

**<Caution>**

- Count down will not be performed if the time set on the count timer is longer than the time required to tighten the screws. Take care when tightening screws with a short thread.

(4) Reverse rotation count timer (RCN-T) settings – for brushless drivers

- Using the F1 switch, change to reverse rotation count timer set mode (function display “ $\Gamma$ ”), loosen a screw and set the reverse rotation time with the F3 switch so that the driver recognizes that the screw has been removed.  
(range of settings: 0.1 to 1.0 seconds. The factory default setting for the reverse count timer is 0.2 seconds)
- Pressing the F1 switch after settings are complete will move to the next item to be set.
- After all settings are complete, press the F1 switch for 1 second or more. A buzzer will sound twice and the setting mode will end.

**<Caution>**

- If the start lever is released after 0.1 seconds has passed for screws with short threads that can be removed within 0.1 seconds of starting reverse rotation, a single count up will be made.
- Take note that a single count up will be made if the reverse rotation is operated for longer than the time set on the reverse rotation count timer even if a screw is not being loosened.

(5) Work reset timer setting

- Using the F1 switch, change to work reset timer setting mode (function display “ $\Gamma$ ”) and set the time on the work reset timer using the F2 (10-digit) and F3 (1-digit) switches.  
(range of settings: 0.0 to 3.9 seconds)
- Set the time on the work reset timer for the DRV LED (operating display) to change from orange to green after the final screw in the set work has been tightened.
- Output of the VALVE signal will stop when the time set on the work reset timer has elapsed.
- Output of the COMP signal will continue for 0.1 seconds after the time set on the work reset timer has elapsed.
- Pressing the F1 switch after settings are complete will move to the next item to be set.
- After all settings are complete, press the F1 switch for 1 second or more. A buzzer will sound twice and the setting mode will end.

(6) Setting count values

- Using the F1 switch, change to screw count setting mode (function display “ $\Gamma$ ”) and set the number of screws using the F2 (10-digit) and F3 (1-digit) switches.

(range of settings: 1 to 99 screws)

- Pressing the F1 switch after settings are complete will move to the next item to be set.
- After all settings are complete, press the F1 switch for 1 second or more. A buzzer will sound twice and the setting mode will end.

(7) System settings

- Using the F1 switch, change to system setting mode (function display “ $\Gamma$ ”) and set the system settings using the F2 (10-digit) and F3 (1-digit) switches.
- The settings available are as follows.
  - a) DSP (controls the remaining screw count display: ON = displayed, OFF = not displayed)
  - b) BUZZ (controls the buzzer sound: ON = buzzer sound on, OFF = buzzer sound off)
  - c) RCN-T (controls the reverse rotation count function: ON = enabled, OFF = disabled)
  - d) EVERON (controls normal counter operation: ON = enabled, OFF = disabled)
  - e) TUP BUZZ (controls the buzzer during torque up operations; ON = enabled, OFF = disabled)
  - f) COUNTER OFF (stops all counter functions: only available for the power supply)



- Settings and functions are as follows.

SW_DSW	X10 (F2)			SW_DSW	X1 (F3)	
MODE	DSP	BUZZ	RCN-T	MODE	EVERON	TUP BUZZ
0	ON	ON	ON	0	OFF	OFF
1	ON	ON	OFF	1	OFF	ON
2	ON	OFF	ON	2	ON	OFF
3	ON	OFF	OFF	3	ON	ON
4	OFF	ON	ON	4	-	-
5	OFF	ON	OFF	5	-	-
6	OFF	OFF	ON	6	-	-
7	OFF	OFF	OFF	7	-	-
8	COUNTER OFF			8	-	-
9	-	-	-	9	-	-

- Pressing the F1 switch after settings are complete will move to the next item to be set.
- After all settings are complete, press the F1 switch for 1 second or more. A buzzer will sound twice and the setting mode will end.

**<Caution>**

- Press the reset switch to cancel any settings you have made. Please note that this will erase all settings you have made.

The above outlines the default settings. Please follow the examples outlined in this manual for all other operations.

■ Basic Timing Chart

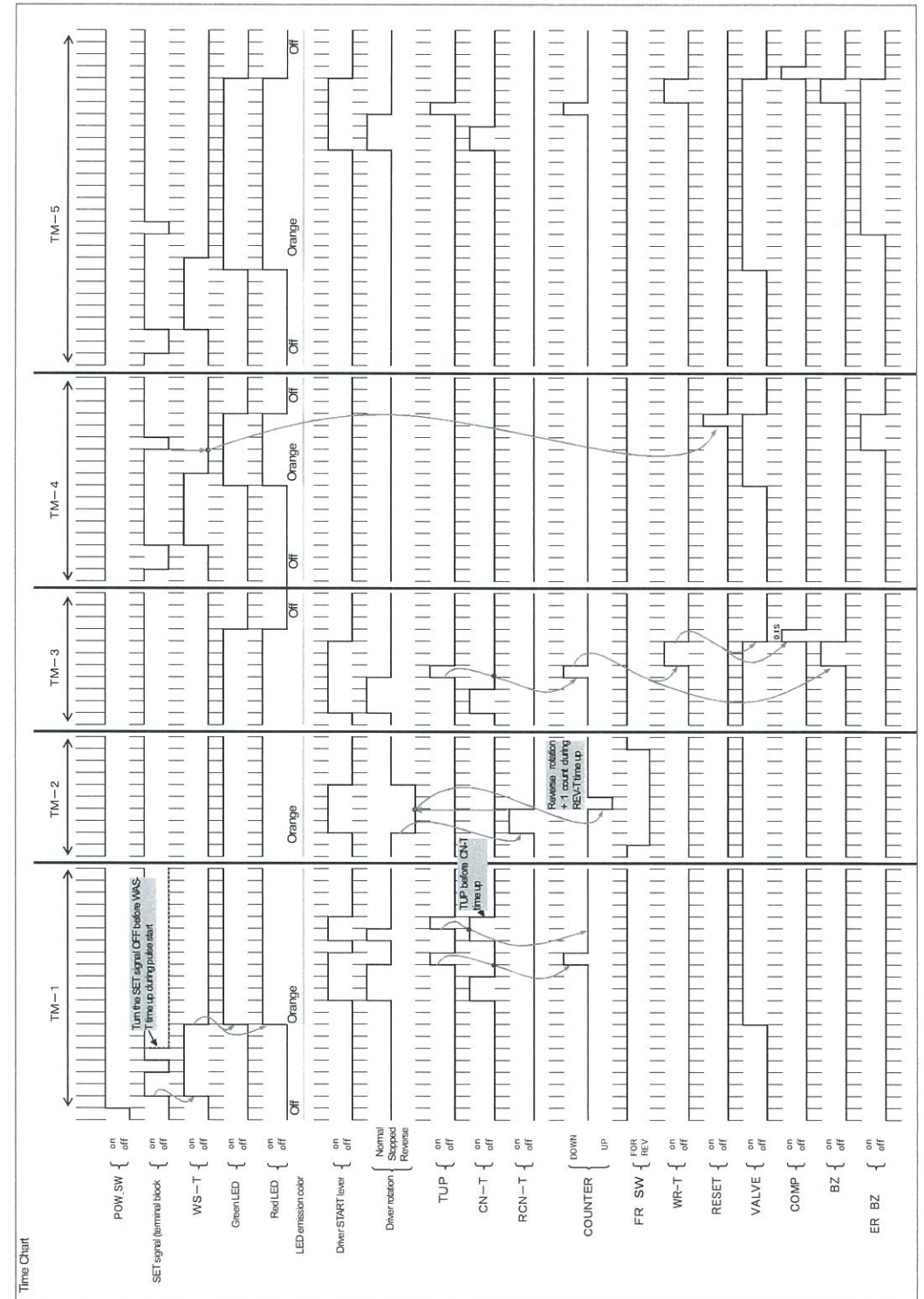

## ■ SC1 Series Outline of Basic Operations

\* The timing chart on the previous page outlines the basic function of the count mode based on the premise that the electronic driver torque has been adjusted, default settings made and the number of screws to be tightened has been entered into the screw counter.

### 1. TM-1 Timing Chart (when tightening screws up until the last screw to be tightened)

- (1) Power "ON"
- (2) Set the work piece and input the SET signal.
  - The unit is designed to operate normally even if the SET signal changes from ON to OFF while the work set timer is operational, or if the signal remains OFF even after time set on the work set timer has elapsed.
- (3) Work set timer operation starts.
- (4) Work set is released and locked again.
- (5) Work set timer operation complete.
- (6) Red DRV LED on the front panel will light up allowing use of the electronic driver.
- (7) VALVE signal output starts.
- (8) Set start lever on the electronic driver to "MANUAL ON".
- (9) Electronic driver operation starts.
- (10) Count timer operation starts.
- (11) Count timer operation complete.
- (12) Torque up after screws have been tightened.
- (13) Electronic driver operation stops.
- (14) Count down starts using the set number of screws to be tightened. The number on the unit display LED decreases one by one.
- (15) Set start lever on the electronic driver to "MANUAL OFF".
- (16) Set start lever on the electronic driver to "MANUAL ON" for tightening checks.
- (17) Electronic driver operation starts.
- (18) Count timer operation starts.
- (19) Immediate torque up for tightening checks.
- (20) Count timer is reset during torque up operation.
- (21) No count down due to torque up during count timer operation.
- (22) Electronic driver operation stops.
- (23) Set start lever on the electronic driver to "MANUAL OFF".

### 2. TM-2 Timing Chart (when loosening screws)

- (1) Set the FOR/REV switch to reverse rotation.
- (2) Set start lever on the electronic driver to "MANUAL ON".
- (3) Electronic driver reverse rotation operation starts.
- (4) Reverse rotation count timer operation starts.
- (5) Reverse rotation count timer complete.
- (6) Count up starts using the set number of screws to be tightened. The number on the unit display LED increases one by one.
- (7) Set start lever on the electronic driver to "MANUAL OFF".
- (8) Electronic driver reverse rotation operation stops.
- (9) Set the FOR/REV switch to reverse rotation.

### <Caution>

- The unit recognizes that a screw has been loosened only when the electronic driver is in reverse rotation longer than the time set on the reverse rotation count timer, and counts up the number of screws in the counter display.
- Please note that count up is not carried out if the start lever is released within the time set on the reverse rotation count timer or reverse rotation is turned "ON" and "OFF" repeatedly when screws are being loosened.
- One count up will occur directly after each count down when put into reverse.
- There will be no count up when no screws have been tightened before the driver is put into reverse rotation in order to loosen a screw.

\* Please note that even if screws are not loosened, the unit will count up if the electronic driver is operated in reverse rotation. This is because there is no torque up signal in reverse rotation.

### 3. TM-3 Timing Chart (when tightening the final screw)

- (1) Set start lever on the electronic driver to "MANUAL ON".
- (2) Electronic driver operation starts.
- (3) Count timer operation starts.
- (4) Count timer operation complete.
- (5) Torque up after screws have been tightened.
- (6) Electronic driver operation stops.
- (7) Count down starts using the set number of screws to be tightened. The number on the unit display LED is "00".
- (8) Work reset timer operation starts.
- (9) Work completion buzzer starts.
- (10) Work reset timer operation complete.
- (11) Work completion buzzer stops.
- (12) Display LED turns green and electronic driver operation is disabled.
- (13) VALVE signal output stopped.
- (14) COMP signal output starts.
- (15) COMP signal output stops after 0.1 seconds.
- (16) Set start lever on the electronic driver to "MANUAL OFF".
- (17) Release the work piece to stop SET signal.

\* Operations after screw tightening is complete

The count is reset with the auto reset function once the last screw has been tightened and the driver will go into standby mode until the next SET signal is received.  
(The electronic driver cannot be used while in standby mode.)

### <Caution>

- In order to enable use of the electronic driver when the first valid SET signal is received, the position of the SET signal (ON, OFF) during work set timer operations will not effect the ER BZ signal.
- The ER BZ signal is only output after the time set on the work set timer has elapsed and if the SET signal changes from ON → OFF.

**<Caution> Loosening screws with reverse rotation after the final screw has been tightened (BLOP-SC1 only)**

- If a screw is to be loosened after the final screw in a particular work piece has been tightened, the electronic driver is only operational while the work reset timer is functional and the work completion buzzer is sounding.
- WR-T (work reset timer) can be adjusted to any value between 0.0 and 3.9 seconds. Any reverse rotation during this time will be recognized as tightening a faulty screw, and even a minor (regardless of the time set on the reverse rotation count timer) reverse rotation will be counted up.

**<Caution>**

- Please note that while it is possible to tighten screws with normal rotation when the work completion buzzer is sounding, the unit will not count down the screws.

**<Caution>**

- Work using a PS type (push start type) electronic driver where the head is rotating freely or work that requires the screw driver to be repeatedly turned ON and OFF such as with short threaded screws can result in an incorrect count. Contact our Marketing Department when working under these conditions.

**4. TM-4 Timing Chart (how to stop error buzzers 1)**

\* Stopping ER BZ terminal signal output using the RESET signal

- (1) The set work is released and the SET signal turns "OFF" momentarily.
- (2) ER BZ output starts.
- (3) System reset with RESET signal input or by manually pressing the RESET switch.
- (4) DRV LED turns off and electronic driver is disabled.
- (5) VALVE signal output stops.
- (6) ER BZ output stops.

**5. TM-5 Timing Chart (how to stop error buzzers 2)**

\* Stopping ER BZ terminal signal output stops using the count down function

- (1) The set work is released and the SET signal turns "OFF" momentarily.
- (2) ER BZ output starts.
- (3) Set start lever to "ON" manually.
- (4) Electronic driver is enabled and work starts.
- (5) Count timer operation starts → stops.
- (6) Torque up, screw tightening complete.
- (7) Electronic driver operation stops.
- (8) Number display "00".
- (9) Work reset timer operation starts.
- (10) Work reset timer operation stops.
- (11) DRV LED turns off and electronic driver is disabled.
- (12) VALVE signal output stops.
- (13) ER BZ output stops.

**■ Basic Usage**

**1. Ordinary Power Mode**

\* When the unit is used as an ordinary power supply for an electronic driver without the use of external equipment control function and counter function, the electronic power for the driver is supplied by the connected HIOS power supply.

**■ Connection**

- (1) Connect the driver cord to the unit's metallic connector.
- (2) Connect the appropriate HIOS power supply for the driver to the metallic power input terminal on the rear panel of the unit.

**■ Setting and Operating Procedures**

- (1) Using the F1 switch, change to system setting mode (function display ") and set to 80.
- (2) Press the F1 Switch for 1 second or more to complete the setting mode.
- (3) After work preparation is complete, tighten screws as per normal.



**2. Continuous counter mode**

\* Do not connect any external equipment to the unit. Use only the screw tightening counter function when carrying out operations. This mode is used as a guideline and to prevent any careless mistakes without setting the work.

**■ Connection**

- (1) Connect the driver cord to the unit's metallic connector.
- (2) Connect the appropriate HIOS power supply for the driver to the metallic power input terminal on the rear panel of the unit.

**■ Setting Procedures**

- (1) Using the F1 switch, change to system setting mode (function display ") and set to 2 (torque up buzzer not used) or 3 (torque up buzzer used) using the F3 switch. Set the F2 switch to 0 to 7 depending on usage conditions.
- (2) Using the F1 switch, change to count setting mode (function display ") and set the number of screws to be tightened.
- (3) Using the F1 switch, change to CN-T setting mode (function display ") and carry out tightening checks while setting the time for the count timer using the set switch (between 0.00 and 0.99 seconds).
- (4) Press the F1 switch for 1 second or more to complete the setting mode.
- (5) This completes the setting procedures.

### ■ Operating Procedures

- (1) Turn the power main switch "ON".
- (2) Tighten the first screw. → The screw count will count down one screw.
- (3) Tighten all screws up to the set number.
  - A buzzer will sound when the number display counts down to "00".
  - The unit will reset automatically and display the initial screw count.
  - The procedure can be repeated.

### 3. Counter Mode

- \* Use the external equipment control function to lock the work piece and set the counter mode if a different electronic driver is to be controlled for each work piece.
- \* Connecting a commercially available total counter allows completed work pieces to be counted.

### ■ Connection

- (1) Connect the driver cord to the unit's metallic connector.
- (2) Connect the appropriate HIOS power supply for the driver to the metallic power input terminal on the rear panel of the unit.
- (3) Refer to Image 1 for each control signal and connect the appropriate cables.

### ■ Setting Procedures

- (1) Turn the connected HIOS power supply "ON".
- (2) Using the F1 switch, change to system setting mode (function display "□") and set to 00.
- (3) Using the F1 switch, change to count setting mode (function display "▮") and set the number of screws to be tightened.
- (4) Using the F1 switch, change to WS-T setting mode (function display "⤴") and set the time on the work set timer to suit the particular work piece using the set switch (between 0.0 and 3.9 seconds).
- (5) Using the F1 switch, change to CN-T setting mode (function display "⤵") and carry out tightening checks while setting the time on the count timer using the set switch (between 0.00 and 0.99 seconds).
- (6) Using the F1 switch, change to WR-T setting mode (function display "⤶") and set the time for the work reset timer to suit the particular work piece using the set switch (between 0.0 and 3.9 seconds).
- (7) Press the F1 switch for 1 second or more to complete the setting mode.
- (8) This completes the setting procedures.

### ■ Operating Procedures

- (1) Input the SET signal
  - Work set timer operation starts.
  - Work set timer operation stops.
  - The VALVE signal is output at the same time.
  - The operating display LED (DRV) turns orange allowing the electronic driver to be used.
- (2) Tightening of the first screw is complete.
  - Tighten the first screw. → The screw count will count down one screw.
- (3) Tighten all screws up to the set number.
  - The work reset timer will start when the number display counts down to "00".
  - The VALVE signal output will stop at the same time.
  - The operating display LED (DRV) will turn off disabling the driver.
  - The work completion buzzer (BZ) will stop at the same time.
  - The COMP signal is output for 0.1 seconds.
- (4) The unit is in standby mode until the next SET signal is input.
- (5) The above procedure is repeated.
- (6) Work complete.

Image 1

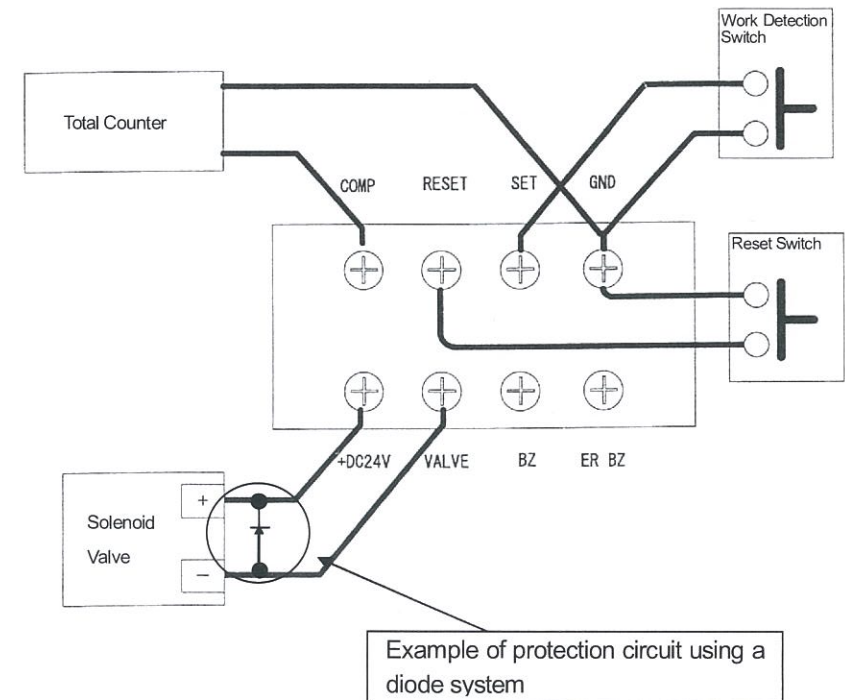

#### 4. Multi-counter Mode

- \* Set this mode if two electronic drivers are operated in a predetermined order with several screws with different torque settings or bit tightening conditions on a single work piece.
- \* This function prevents the erroneous use of one driver while another driver is being used.
- \* Connecting a commercially available total counter allows completed work pieces to be counted. Connecting the unit in a daisy chain setup allows you to increase the number of work pieces.
- When two units are used, the first to be used is referred to as "A" and the second is referred to as "B".

#### ■ Connection

- (1) Connect the driver cord to the unit's metallic connector.
- (2) Connect the power cord of the HIOS power supply connected to the unit to the specified rated power supply voltage (AC power outlet) and connect to ground.
- (3) Refer to Image 2 for each control signal and connect the appropriate cables.

#### ■ Setting and Operating Procedures

- (1) Set "A" according to the following.

- Using the F1 switch, change to system setting mode (function display "d") and set to 20.
- Using the F1 switch, change to count setting mode (function display "n") and set the number of screws to be tightened.
- Using the F1 switch, change to WS-T setting mode (function display "s") and set the time on the work set timer to suit the particular work piece using the set switch (between 0.0 and 3.9 seconds).
- Using the F1 switch, change to CN-T setting mode (function display "c") and carry out tightening checks while setting the time on the count timer using the set switch (between 0.00 and 0.99 seconds).
- Using the F1 switch, change to WR-T setting mode (function display "t") and set the time on the work reset timer to 0.0 seconds.
- Press the F1 switch for 1 second or more to complete the setting mode.

- (2) Set "B" according to the following.

- Using the F1 switch, change to system setting mode (function display "d") and set to 20.
- Using the F1 switch, change to count setting mode (function display "n") and set the number of screws to be tightened.
- Using the F1 switch, change to WS-T setting mode (function display "s") and set the time on the work set timer to suit the particular work piece using the set switch (between 0.0 and 3.9 seconds).
- Using the F1 switch, change to CN-T setting mode (function display "c") and carry out

tightening checks while setting the time on the count timer operating time using the set switch (between 0.00 and 0.99 seconds).

- Using the F1 switch, change to WR-T setting mode (function display "t") and set the time on the work reset timer to suit the particular work piece using the set switch (between 0.0 and 3.9 seconds).
- Press the F1 switch for 1 second or more to complete the setting mode.

- (3) This completes the setting procedures.

Image 2

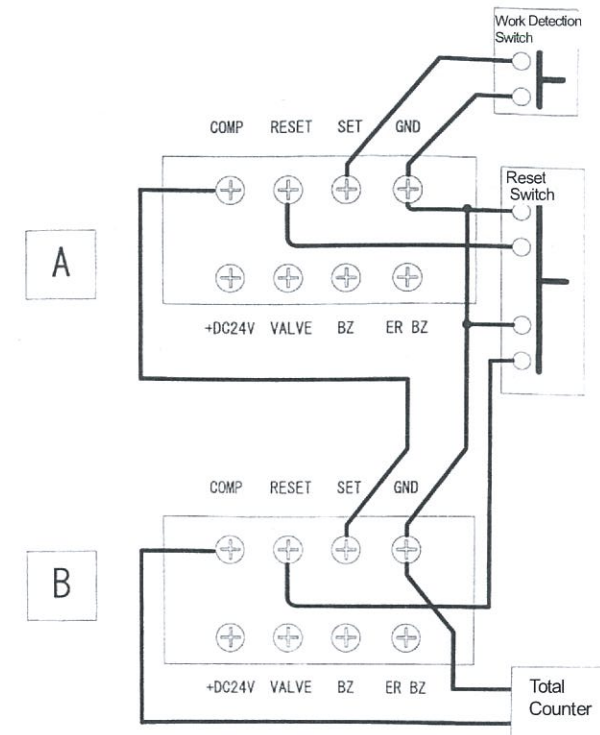

## ■ Troubleshooting

Use the following table to check for problems and contact the store of purchase or our service department if you have any problems.

Problem	Solution
The unit does not power up	(1) Check whether the connected HIOS power supply is operating correctly. - Check whether the power cord is connected to the rated voltage power outlet. - If the power cord is loose, connect it properly and turn the power supply main switch on again. - Check whether the fuse has blown.
The counter function does not operate	(2) Request repairs by our service department.

Contact the store of purchase or our service department if you have any inquiries regarding after sales service.